

Oil King,[™] Coolant King[™] and Oil Ace[™]

Fluid Reclaim Packages and Accessories

Oil King and Coolant King

- Large 25 gallon capacity with sight gauge
- Convenient tool trays and filter areas
- Large offset collection pan with screen
- Oversized tires to get over hose and rough floors
- Color specific receiver for easy identification

Typical Applications

- Used fluid receiver
- Automotive dealerships
- Heavy-duty dealerships
- Fast lube centers
- Fleet service facilities
- Service shops

Typical Fluids Handled

- Used oil—Oil King
- Used antifreeze—Coolant King

Ordering Information

Oil King Oil Receiver	
238866	25 gal (95 l) Polyethylene tank with used-filter tray, tool holders and sight gauge. Includes all hardware for topside evacuation or bottom drain*. Instruction manual 308667
Coolant King Anti-Freeze Receiver	
248632	25 gal (95 l) Polyethylene tank with used-filter tray, tool holders and sight gauge. Includes all hardware for topside evacuation or bottom drain*

* Must use 224873 for topside evacuation. Must ship via truck.

Oil Ace

- Easy to drain using shop air pressure
- Large 24 gallon capacity
- Large offset collection pan with screen

Typical Applications

- Pressurized used oil receiver
- Automotive dealerships
- Heavy-duty dealerships
- Service shops
- Fast lube centers
- Fleet service facilities

Typical Fluids Handled

- Used oil

Ordering Information

Oil Ace	
119577	24 gal (90 l) Steel-tank Pressurized Oil Drain



Oil Receivers and Drains

Fluid Reclaim Packages and Accessories

Ordering Information

16 gal (60 l) Used-Oil Receiver with drum	
239301	Use with evacuation kit 240832. Instruction manual 306449
16 gal (60 l) Used-Oil Receiver without drum	
239302	Instruction manual 306449
Funnel Kit	
243650	Use with 238866, 239301, 239302 and 248632. Includes tray and pipe
Wall-Mounted Funnel Drain	
154616	Use with Pedestal Receiver 225272 to open automatic check-valve and drain used oil through wall to waste tank. Drain has 1-1/4 npt(f) outlet
Drum-Mounted Funnel Drain	
156789	Use with Pedestal Receiver (225272) to open automatic check-valve and drain used oil into standard drum. Funnel drain has 2 npt bung fitting for use with 55 gal (210 l) or 16 gal (60 l) drums, or 275 gallon (1,100 l) tanks
ATF Drain Funnel	
208009	Use with Pedestal Receiver (225272) to extend funnel reach. Use for draining transmissions. (Not equipped with drain plug.) 16 in x 24 1/2 in
Rolling Used-Oil Receiver	
218969	Specially designed for car and truck fast-lube facilities where speed and mobility are important. Adjustable steel rollers fit track widths of 39 in (99 cm) to 46 inches (117 cm), with a minimum running width of 2-1/2 in (63.5 mm). Front and rear drain fittings allow use of two drains on a single track, permitting two receivers to be drained simultaneously. Instruction manual 307727. Unit includes 30 gal (114 l) steel tank, 1-1/2 npt drain valve (108204), 1-1/2 npt quick coupler (108202) and 1-1/2 npt coupler cap. Dimensions: 24 in (61 cm) wide; 33 in (84 cm) long; 11 in (28 cm) deep; 3 in (7.6 cm) diameter wheels. 1-1/2 in drain hose—see manual provided
Narrow Rolling Used-Oil Receiver	
235346	Same as 218969 above, except track width range is from 34.2 in (87 cm) to 42.2 in (108 cm). 27 gal (102 l) capacity. Instruction manual 307727. See accessories on page 101
Big Hauler™ Truck Drain	
244055	Specially-designed for truck maintenance facilities, the Big Hauler Truck Drain boasts a large capacity and easy maneuverability. Dimensions: 42 in (106.7 cm) long; 30 in (76.2 cm) wide; 9 in (22.9 cm) deep. Capacity: 26 gallons (98 l). Instruction manual 309194. Gravity drain valve at bottom of unit allows for easy drain access. 3/4 in npt outlet can also be used with 224873 for diaphragm evacuation. 240832 can be ordered separately for existing diaphragm pump evacuation systems. Instruction manual 308719



239301



244055



208009



218969

Oil Evacuation

Fluid Reclaim Packages and Accessories

Packages for Used-Oil Evacuation with Air-Operated Diaphragm Pumps

Wall-Mounted Packages	
24E166	Includes: 1050A (1 in) diaphragm pump (647016), wall bracket (189233), air installation kits (240684), fluid installation kits (240685), drum style adapter kits (240832) <i>NOTE: Used-oil receivers are not included and must be ordered separately. See instruction manual 313597 for more information.</i>
224873	Includes: 716 (3/4 in) diaphragm pump (241906), wall bracket (224835), air installation kits, fluid installation kits (240685), drum style adapter kits (240832) <i>NOTE: Used-oil receivers are not included and must be ordered separately.</i>

Stationary Gear-Oil Evacuation Systems with 716 or 1050 Diaphragm Pump

System evacuates lube from differential case using suction generated by a diaphragm pump. Nylon tubes ranging in size from 3/16 in OD to 1/2 in OD are included to fit through sight plug to completely drain the case. Evacuated gear lube is then pumped to waste tank. Piping and waste tank not included. Systems are fully-groundable and bondable for safe transfer of used oil

224955	Includes: 716 diaphragm pump (241906), air control kit (110149), mounting kit (224759), swivel union (157785), hose coupler (111474), suction hose/wand** (221146) and control valve** (220969) <i>**Order additional suction hose/wand (221146) and additional control valve (220969) for each additional suction point. Note: Order grounding clamp (222011) or use locally-supplied grounding wires and clamps in accordance with applicable codes.</i>
24E167	Includes: UL-listed 1050A diaphragm pump (647016), air control kit, hose and fitting kit (222149), evacuation, suction hose/wand** (221146) and wall bracket (189233) <i>**Order additional suction hose/wand 221146 and additional control valve 220969 for each additional suction point. Note: Order grounding clamp 222011 or use locally-supplied grounding wires and clamps in accordance with applicable codes. See instruction manual 313597 for more information.</i>

Port-Evacuation Pump

Port-Evacuation allows fast, clean withdrawal of gear lube, ATF, anti-freeze, and related fluids. Includes: 716 diaphragm pump (241906), mounting kit with 10 ft (3 m) suction hose (223697) which attaches to wands of four different diameters (suction wand kit, 223696): 1/2 in (12.7 mm); 3/8 in (9.5 mm); 1/4 in (6.4 mm), and 3/16 in (4.7 mm). Instruction manual 308035

Suction Wand Kits	
223696	15 in (38.1 cm)
224762	48 in (121.9 cm)
223696	15 in (38.1 cm)
224762	48 in (121.9 cm)

Used-Oil Handling Accessories

Tandem Drain Kit	
218970	Tandem drain kit connects two rolling receivers for flow-through draining operation. Kit includes connector hose, shut-off valve, pipe nipple, and quick-connect nipple. Instruction manual 307727
108491	Drain hose kit allows rolling used-oil receiver to be drained directly into the used-oil line. Kit is 24 in (0.6 m) in length with camlock coupler on one end

Swing-Arm Drain Kit

Used for servicing single rolling used-oil receiver (218969). When used with tandem drain kit (218970) it can service two receivers on a single track. Kit includes swivel elbow (108867), connector hose, dust cap (108203) and male adapter (108202)

Oil Tank Monitor

116229 Shuts off air to the pump when tank is full. Mounted at either end of fast lube service pit, swing-arm drain stores against pit wall and is rotated into position for use

Accessories for Port-Evac Pump (223695)

223888 6 ft (1.8 m) suction hose for ATF and anti-freeze. Includes filter screen

Fluid Reclaim Accessories

243167	U-tube for used-oil drain cart evacuation system. 1/2 npt (mbe)
222011	Grounding clamp for all used-oil handling systems includes 25 ft (7.6 m) grounding wire

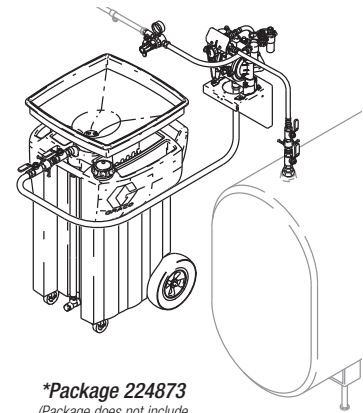

***Package 224873**
(Package does not include 238866 receiver or tank)

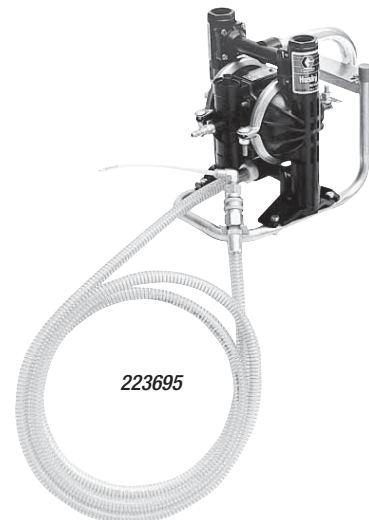

Oil Evacuation

Fluid Reclaim Packages and Accessories

Fas-Vac Evacuation Systems

224667*	Fas-vac evacuation system (without drum) basic system includes 716 diaphragm pump and mounting hardware. Instruction manual 308154
224700*	16 gallon (60 l) system includes pump (224667), dolly (224665), wand storage kit (224666), evacuation hose (224669) and 16 gallon (60 l) drum (111468). Instruction manual 308154
224701*	55 gallon (200 l) system (without drum) includes pump (224667), 55 gallon (200 l) drum truck (111470), wand storage kit (224666) and evacuation hose (224702). Instruction manual 308154
187359	4-way valve 1/2 npt(f) ports

*224759 FLR mounting kit and 110149 FRL must be ordered separately. See instruction manual 308163.

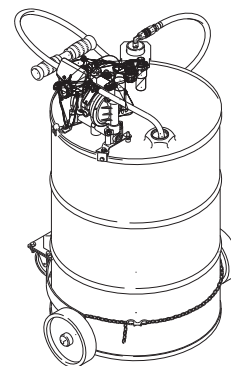

224701

Hoses, Fittings and Accessories

Air Filters

Centrifugal action 1/4, 3/8 and 1/2 npt. (with 20 micron filters); 3/4 npt having 40 micron filters to remove water and foreign particles from air supply

110146	1/4 npt(fbe)	106148	3/8 npt(fbe)
106149	1/2 npt(fbe)	106150	3/4 npt(fbe)

Automatic Filter Drain

106151 Float-type drain for automatic emptying of accumulated fluid in a filter assembly. 1/4 npt(m) (does not fit air filter 110146)

Air Regulators

Provides precision control of outlet air pressure. Feedback principle provides constant pressure to pump regardless of air demand rate and fluctuations in supply pressure. (Additional fittings required except air regulators with installation kits.)

110318	1/4 npt(fbe)
110147	1/4 npt(fbe) with gauge
110234	3/8 npt(fbe)
109075	3/8 npt(fbe) with gauge
202858	3/8 npt(m) x 1/2 npsm(f) with gauge
104266	1/2 npt(fbe)
244844	1/2 npt(fbe) with gauge
207755	3/4 npt(fbe)
244845	3/4 npt(fbe) with gauge

Installation Kits

Installation kits include: shut-off valve, regulators, gauges and fittings as necessary for normal installation

218316	Installation kits for Fast-Flo, Fire-Ball, or Husky 307 and 716 diaphragm pumps
224512	Installation kits for Mini Fire-Ball 225 and Fire-Ball

Air Lubricators

Extends pump life and smooths pump movement by applying measured lubricant to all moving parts within the pump air motor. Control knob and sight window allow adjustment of dispensed lubricant

214848	1/2 npt(fbe)
110148	1/4 npt(fbe)
214847	3/8 npt(fbe)
214849	3/4 npt(fbe)



106148



106151



109075



224512



214847