



XL Series

Shock-Resistant, Ductile Iron Pumps

Design Features

The XL pumps are constructed of ductile iron (ASTM 536, 18% Elongation) that will withstand sudden thermal shock and stress well beyond the capabilities of cast iron. All models are fitted with replaceable casing liners and end discs that allow easy rebuilding of the pump, without removing the pump from the piping.

Models are available in 1.25, 1.5, 2, 3 and 4-inch port sizes with capacities from 5 to 345 gpm (19 to 1,305 lpm). The 1.25 and 1.5-inch models have NPT tapped ports. The 2, 3 and 4-inch models have flanged ports.

Standard elastomers include FKM O-rings. Optional Buna-N or PTFE elastomers are available. A wide range of mechanical seal components and a variety of vane materials are optional.

The X(R)L1.25 and XL1.5 motor speed pumps are base mounted. The X(R)LF1.25 and XLF1.5 models are fitted with an integral bracket for direct mounting to a NEMA C-face motor. Base mounted unit assemblies with helical gear reduction drive are available for all XL models.

Application

Blackmer XL type pumps are commonly used in refineries, lube oil plants and general industry for processing, filling and transfer applications.

Benefits

Utilizing Blackmer's unique sliding vane designs, these positive displacement rotary pumps offer the best combined characteristics of sustained high level performance, energy efficiency, trouble-free operation and low maintenance cost.

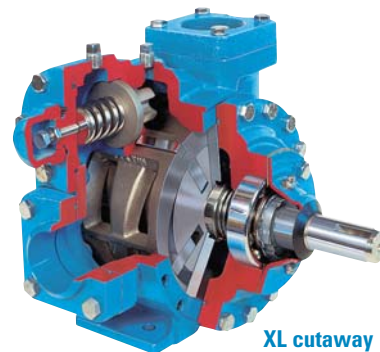

XL cutaway



X(R)LF1.25, XLF1.5



X(R)L1.25, XL1.5-DM



X(R)L1.25, XL1.5 cutaway

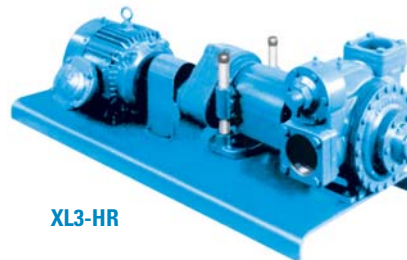

XL3-HR

How Blackmer's sliding vane action works

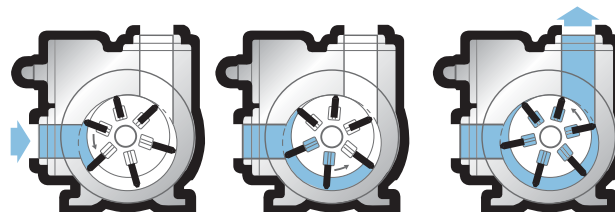



XL Series Shock-Resistant, Ductile Iron Pumps

Pump Performance Data*

	Pump Model																							
	XRL1.25 XRLF1.25				XL1.25 XLF1.25				XL1.5 XLF1.5				XL2				XL3				XL4			
Speed (RPM)	1800	1500	1200	1000	1800	1500	1200	1000	1800	1500	1200	1000	780	640	520	420	780	640	520	420	640	520	420	350
U.S. GPM	17	14	11	9	23	19	15	12	34	28	22	18	88	72	57	47	183	149	120	95	344	280	225	187
LPM	64	53	42	34	87	72	57	45	129	106	83	68	333	273	216	178	693	564	455	360	1303	1061	852	708
HP	1.2	0.9	0.8	0.6	1.4	1.1	0.9	0.7	1.8	1.6	1.2	0.8	4.0	3.2	2.5	1.9	8.0	6.3	5.0	3.9	15.0	11.1	8.3	6.5

* Approximate capacities and horsepower (HP) are based upon a 100 Ssu (22 cSt) liquid at 50 PSI (3.45 bar) differential pressure. Refer to characteristic curves for capacities and horsepower at other pressures and viscosities.

Maximum Operating Limits

Pump Model	Nominal Flowrate		Pump Speed	Viscosity		Differential Pressure		Working Pressure		Temperature	
	gpm	L/min	rpm	ssu	cSt	psi	bar	psi	bar	°F	°C
XRL(F)1.25	17	64	1800	50,000	10,625	150	10.3	350	24.1	300	148
XL(F)1.25	23	87	1800	30,000	6375	150	10.3	350	24.1	300	148
XL(F)1.5	35	132	1800	20,000	4250	150	10.3	350	24.1	300	148
XL2	95	359	780	75,000	15,750	150	10.3	350	24.1	300	148
XL3	192	726	780	75,000	15,750	150	10.3	350	24.1	300	148
XL4	345	1306	640	60,000	12,600	150	10.3	350	24.1	300	148

* For applications that require higher capacities, please refer to Blackmer Spec Sheets 102-002 and 106-004 for the HXL and ML4 pump series. Note: Optional materials of construction may be required to meet specific application requirements – refer to Blackmer Material Specification Sheets. For operating conditions that exceed those listed, consult factory.

Companion Flanges

Pump Model	Standard	Optional
XRL1.25 XL1.25 XRLF1.25 XLF1.25	1½" NPT Tapped Ports	–
XL1.5 XLF1.5	1½" NPT Tapped Ports	–
XL2	2" NPT	2" Weld 2" ANSI 150#
XL3	3" NPT	3" Weld 3" ANSI 150#
XL4	4" Weld	3" NPT

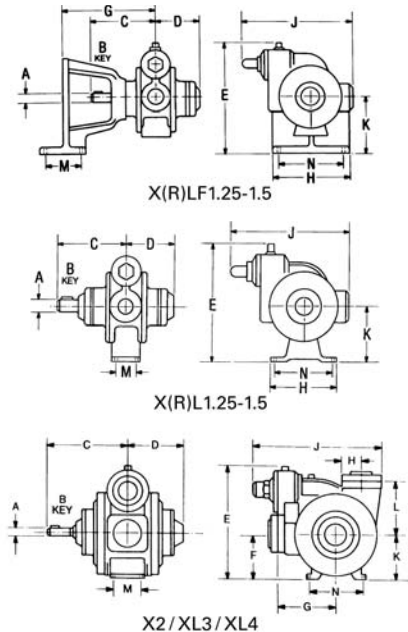

Dimensions

Pump Model	A	B	C	D	E	G	H	J	K	M	N	Approximate Wt. Less Motor
XRLF1.25 XLF1.25 XLF1.5	in. ¾	¾	5½	3¾	8¾	8¾	6¾	9¾	4½	2¾	5¼	39 lb
	mm –	–	140	98	225	205	168	232	114	60	133	18 kg

Pump Model	A	B	C	D	E	G	H	J	K	M	N	Approximate Wt. Less Motor
XRL1.25 XL1.25 XL1.5	in. ¾	¾	5½	3¾	8¾	–	5½	9¾	4½	1¾	4	30 lb
	mm –	–	140	98	225	–	140	232	114	35	102	14 kg

Pump Model	A	B	C	D	E	F	G	H	J	K	L	M	N	Approximate Wt. Less Motor
XL2	in. 1½	¾	8	5½	10	3¾	4 13/16	2¾	11 1/16	4	4¾	1¾	5	85 lb
	mm –	–	203	138	254	95	122	60	281	102	124	41	127	39 kg
XL3	in. 1½	¾	9¾	6¾	13¾	5¾	7	3¾	15 1/16	5¾	6¾	2½	6	160 lb
	mm –	–	245	160	340	137	178	79	383	137	160	64	152	73 kg
XL4	in. 1¾	¾	9¾	6¾	15 1/16	4¾	6¾	2¾	16 15/16	5 13/16	7½	2½	8¾	205 lb
	mm –	–	245	172	392	124	168	67	430	151	190	64	210	93 kg

Sales Information and Equipment Application Assistance

Blackmer has a world wide distribution network to assist you in specifying any of our family of pumps, compressors and other equipment for your application. For more information or to find the distributor nearest you, please contact us at the telephone, fax or internet address listed below.



Distributed by:

World Headquarters
1809 Century Avenue SW
Grand Rapids, MI 49503-1530 USA
T 616.241.1611 F 616.241.3752



www.blackmer.com